

TECHNICAL SHEET



Description	Dimensions	Weight	Code
DA 2001	1052x535x848 mm	108 kg	7041501

DA 2001 dehumidifier shall be combined with radiant cooling, and it is suitable for medium-sized commercial applications and medium occupant density spaces. Operations: air dehumidification, air recirculation, and ability to handle sensible load in the summer and winter. The unit housing is made of galvanised sheet metal, and it contains finned coils for the air handling, the refrigerant circuit for the dehumidification, the air intake filter, the condensate collection vessel, the high-efficiency supply fan and the wiring box. The unit is equipped with a display to show and set the different parameters.

- Nominal air flow rate: 2000 m³/h
- Available pressure: 365 Pa
- Dehumidification capacity: 246 l/24h (26 °C RH 65% water temperature 15 °C)
- Pre-treatment + condensing water flow rate at 15 °C: 2250 l/h
- Additional sensible cooling capacity up to 8456 W with supply water at 15 °C (26 °C RH 65%)
- Maximum power consumption: 3070 W
- 1 mandatory syphon

COMPONENTS

AIR FLOWS



Ricirculation
Air



Supply
Air

AIR FILTERS

Classes, Minimum Efficiency, Type of Particulate



e(PM10) min ≤50 %
Hairs



Hydraulic connection



Ø 20 mm Condensation Drain



Wiring Box

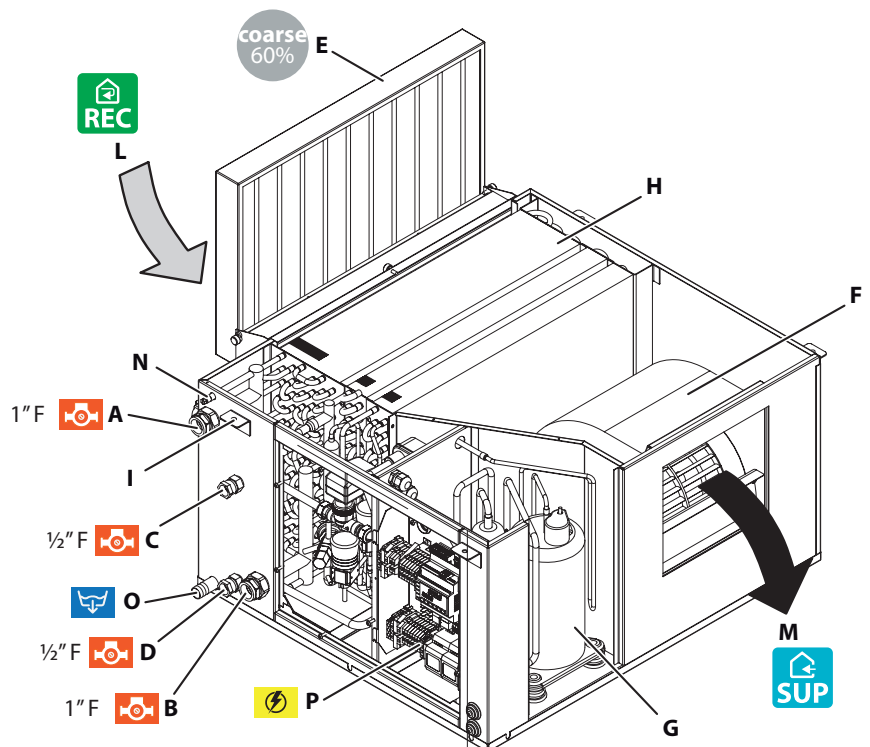

Rif.	Description	Rif.	Description
A	Pre-treatment water outlet (1" F)	L	Air inlet
B	Pre-treatment water inlet (1" F)	M	Dehumidified air outlet
C	Condenser water outlet (1/2" F)	N	Vent
D	Condenser water inlet (1/2" F)	O	Ø 20 mm Condensation drain
E	Filter	P	Wiring box
F	Fan		
G	Compressor		
H	Finned pack		
I	Fixing brackets (Ø 8 mm hole)		

TECHNICAL SHEET

DIMENSIONS AND TECHNICAL DATA

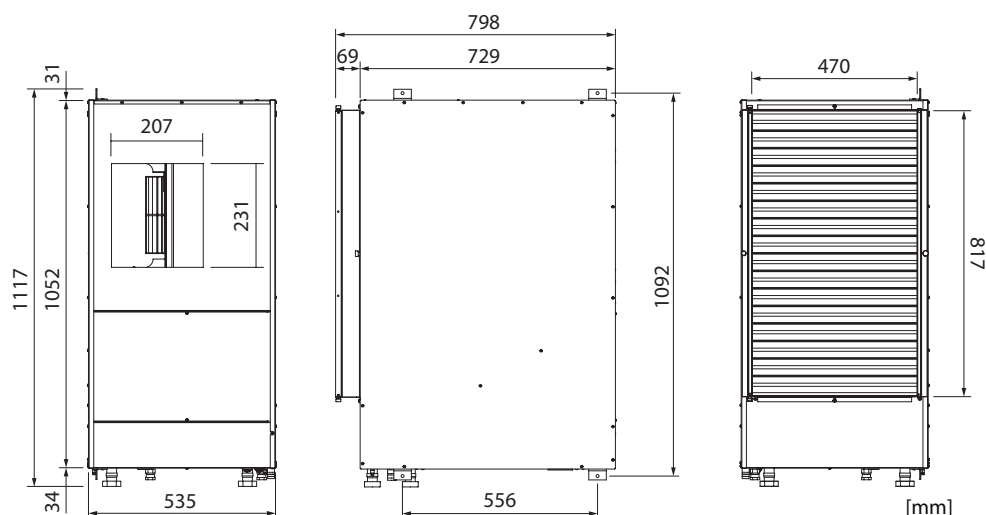

Overall unit dimensions	
Height	535 mm
Width (without hydraulic connect.)	1052 mm
Depth	798 mm
Weight	108 kg
Unit packaging	
Height	655 mm
Width	1200 mm
Depth	855 mm



Technical characteristics

Technical specifications

Condensation (26° - 65%)		l/day	246
Standard voltage		A	13,9
Max electrical power absorbed by the compressor		W	2070
Max electrical power absorbed by the fan		W	1000
Total max power consumption of the fan		A	2,9
Nominal air flow rate		m ³ /h	2000
Available head	Only DA	Pa	365
	DA + SR		163
Pre-cooling water flow rate		l/h	2000
Pre-cooling water outlets			3/4" F
Condensation water flow rate		l/h	250
Condensation water outlets			1/2" F
Pre-cooling water head loss	Only DA	kPa	12,6
	DA + Modulating Valve		28,6
Refrigerant (R410A) - GWP: 2088		gr	2500
Carbon dioxide equivalent		t	5,22
Maximum operating pressure		Bar	39

MANDATORY COMPLEMENTS

The installation of no. 1 Condensate drain choosing, according to the needs, among those proposed.

Condensate drain		Code
	SF-M 20 Condensate drain kit consisting of a siphon with silicone membrane, hose and fitting, to be used in combination with RDZ air handling units.	3600400
	SF-P N Condensate drain kit with casing, designed for wall installation. It can be used in combination with RDZ air handling units, and it is suitable for Ø 20-32 mm piping. The external shell can be adjusted considering the thickness of the wall. Washable internal cartridge.	7045504

ACCESSORIES

Hydraulics	Code	Hydraulics	Code
	MP 20-70 Ø1" Flow Meter - Kv 12,9		MODULATING VALVE Ø 1" 3-way valve with 0-10V modulating servomotor, power supply 24V, Kvs 6.3
	7045559		7041190

TECHNICAL SHEET

SPARE PARTS

Air filter kit		Code
	DA 2001 FILTER KIT Kit for complete replacement of unit filters containing: • 1 ISO Coarse 60% filter - Size 815x490x50 mm	7044185

OPERATING LIMITS

Summer operation: the maximum permissible water temperature in summer operation is 18 °C. Above 19 °C, the compressor is excluded, leaving only the fan running.

Winter operation: permissible water temperature in winter operation <55 °C. At higher temperatures, the appliance may be damaged.

SUMMER PERFORMANCE

Performance in dehumidification mode, according to the temperature, relative humidity and temperature of the chilled water.

Only DA 2001 - Performance in dehumidification/integration mode										
Inlet air		Outlet air		Latent cooling power		Minimum inflow air temp. °C	Sensible cooling power		Cooling power to be supplied to the unit	
°C	% UR	°C	% UR	W	l/g		Max	Set 17 °C	Dehumidific.	Integration
26	55	26	43,2	4300	148,5	13,9	8456	6300	7430	15886
26	65	26	45,8	7030	242,8	14,8	7812	6300	10161	17973

DA +SR 2001 - Performance in dehumidification/integration mode										
Inlet air		Outlet air		Latent cooling power		Minimum inflow air temp. °C	Sensible cooling power		Cooling power to be supplied to the unit	
°C	% UR	°C	% UR	W	l/g		Max	Set 17 °C	Dehumidific.	Integration
33	50	26	49,3	9617	332,1	16,0	7021	6300	14777	21798
35	50	26	52,2	11890	410,6	16,8	6412	6300	17610	24022

WINTER PERFORMANCE

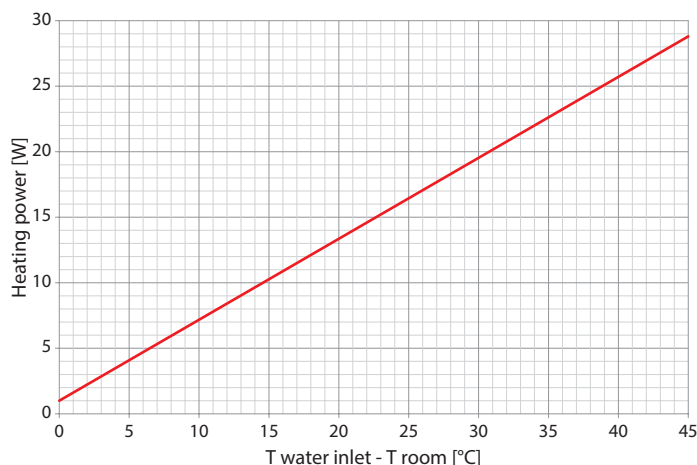

PRESSURE LOSS OF THE HYDRAULIC CIRCUIT

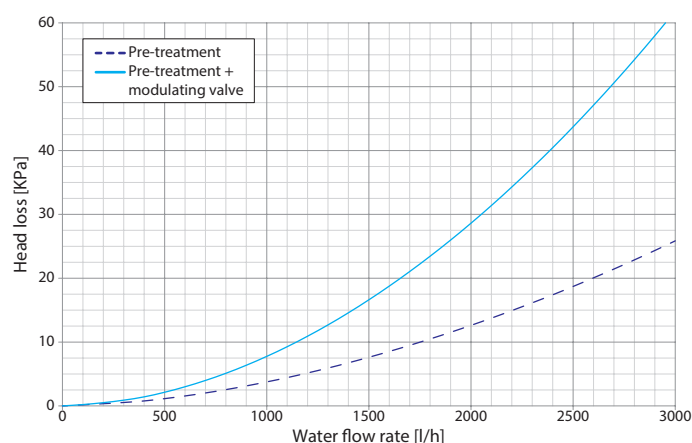

Maximum sensible heating capacity according to the temperature difference between inflow air into the unit and water.

TECHNICAL SHEET

AVAILABLE PRESSURES TO THE INTAKE OUTLET

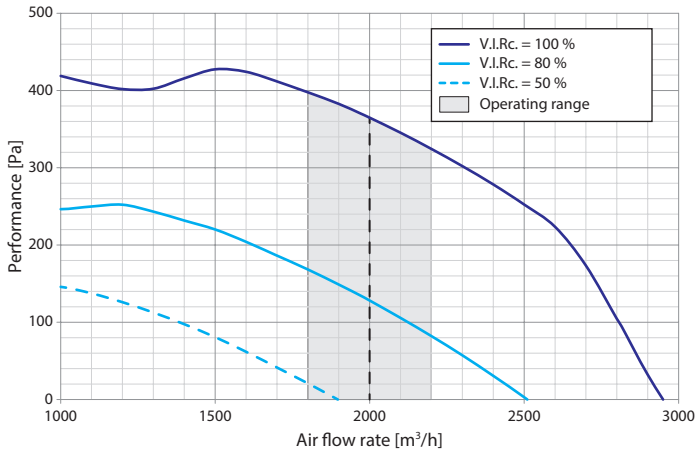

V.I.Rc. : Recirculation Air inlet Speed

HEAT RECOVERY SR PRESSURES DROP

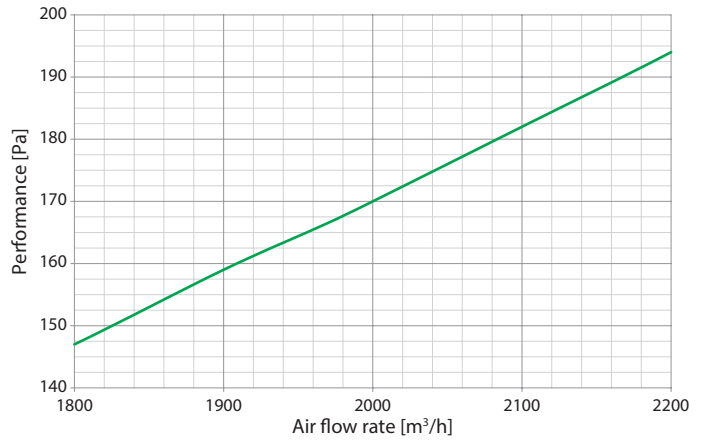

Pressure drop value in SR units, which should be subtracted from the aeruic performance of the DA units in case of combination into UC units.

ACOUSTIC CHARACTERISTICS

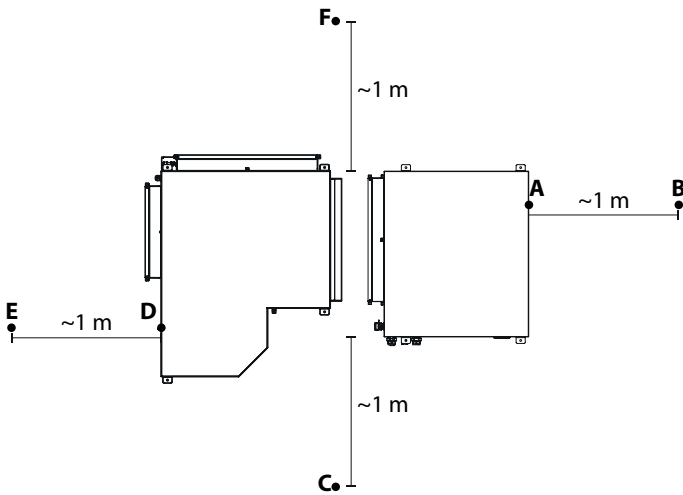

Sound pressure detected								
Operation	Speed [%]	A	B	C	D	E	F	
		[db(A)]						
Air recirculation	40	81	65	54				
Dehumidification	40	82	65	56				
Dehumidification	30	80	61	55				
Dehumidification	100	84	71,5	60				
Ventilation	40		60		78	62	57	
Ventilation	30	78	63		80	61		
Bottom 35 db(A)								

The detected acoustic value can be further improved thanks to the noise reduction offered by the presence of the plasterboard ceiling where the machine is installed.



It is highly recommended to install a silencer near the unit, especially near the supply line.

POSITIONING TO THE CEILING

